

Simulink Basics Tutorial

Chenda Liao

Closed-loop Control System

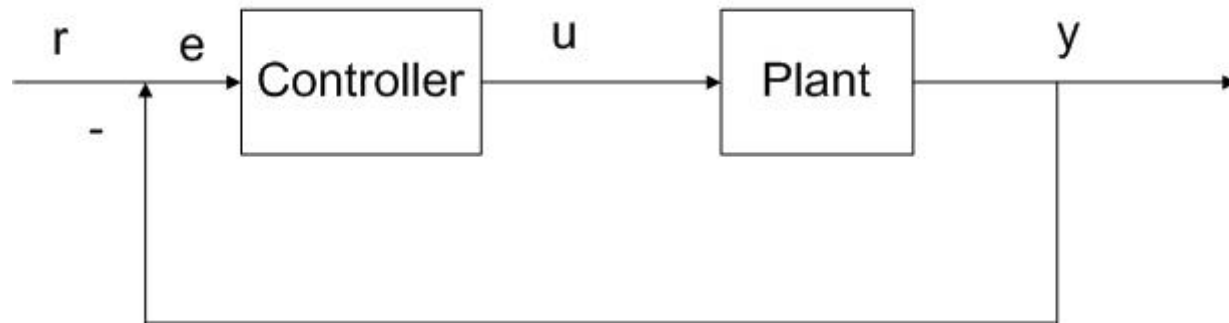

Plant Model

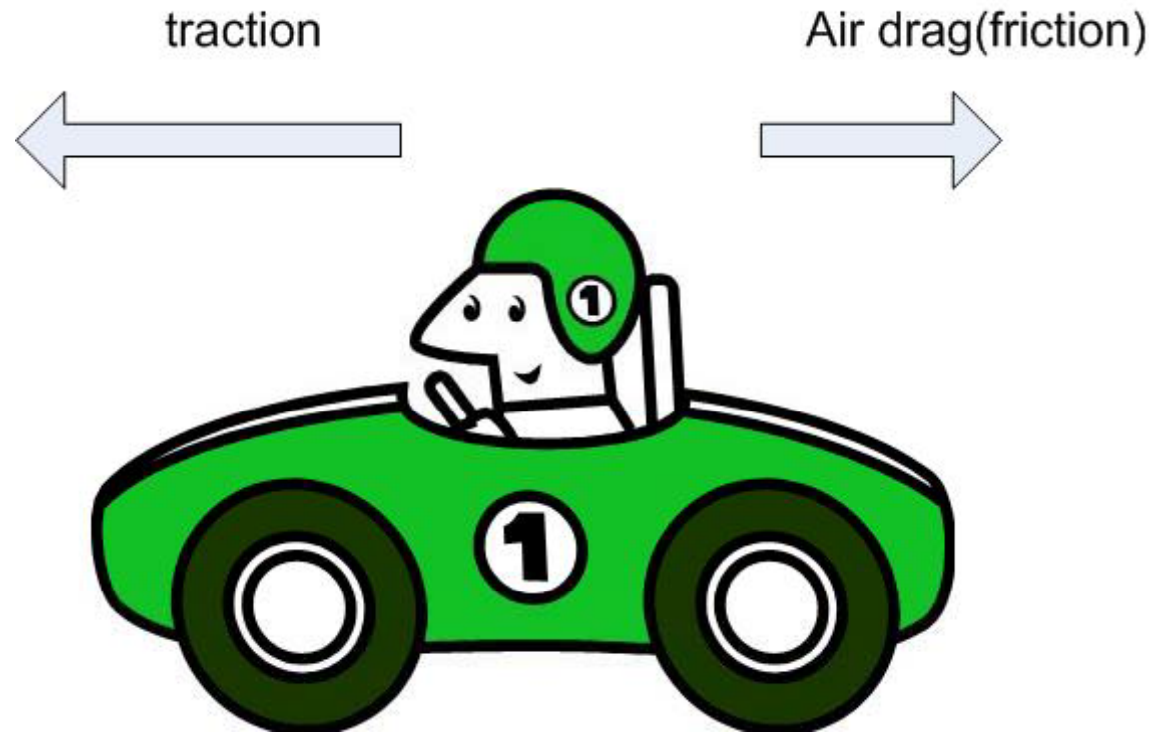

$$m * dv = a\theta - bv^2$$

Plant Model

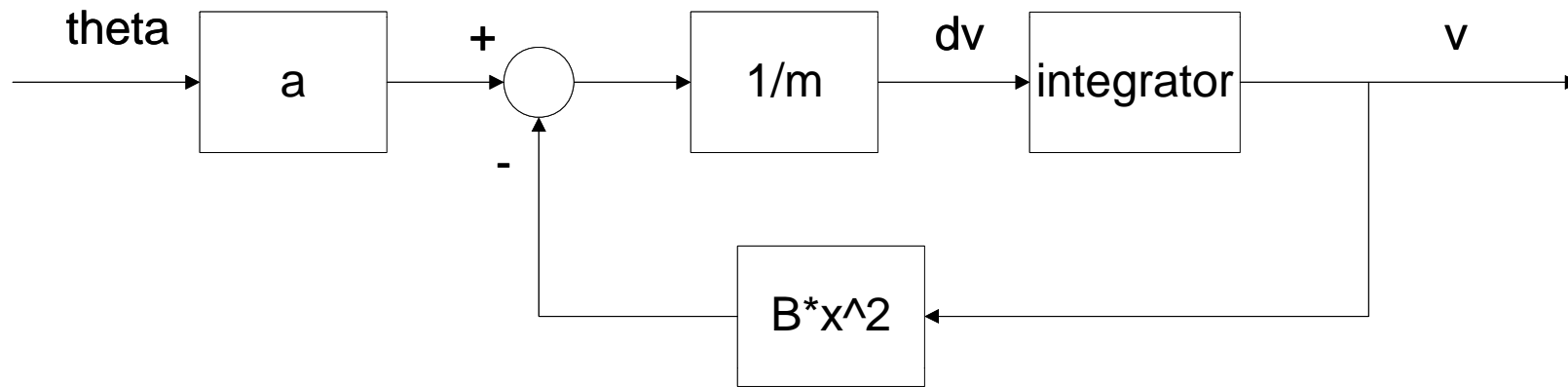

$$dv = \frac{a\theta - bv^2}{m}$$